

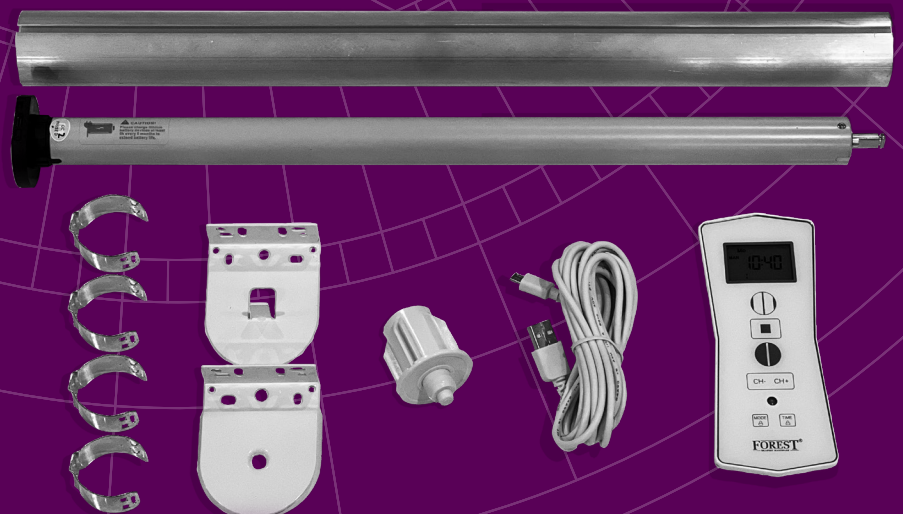

FOREST ENDEAVOR Build Your Own Roman

This is a versatile build your own motorized Roman blind system

THE WORLD
BEHIND
YOUR
DRAPERIES



FOREST ENDEAVOR



Scan for more information on
FOREST ENDEAVOR Make Your Own
Romans

ENDEAVOR BUILD YOUR OWN MOTORIZED ROMANS















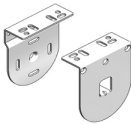

- Our Endeavor system allows you to make your own Romans and use the same controls as your motorized drapery hardware.
- 1 1/2" / 38mm tube with a 1.8 Nm tubular motor. Recommended maximum weight per shade is 16 lbs.
- Motor includes crown and drive.
- Easy charging with a usb-c cable included in your kit.

ENDEAVOR KIT

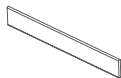
Includes 1 1/2" / 38mm tube, motor, drive, crown, end plug, brackets, clips (4 for the first 4 feet and 1 per each additional foot), charging cable and Forest Diamond Sense remote, wall switch or EasyTouch remote.

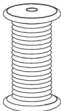
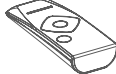
FOREST ENDEAVOR

ENDEAVOR	COMPONENT	ENDEAVOR	COMPONENT
•	 <p>71119-90 1 1/2" / 38mm 19' Tube, aluminum</p>	•	 <p>49014-25 Plastic Snap Ring</p>
•	 <p>72309ED-25 End Plug</p>	•	 <p>49013-25 Plastic Ring Cord Guide</p>
•	 <p>72306-25 Multi-Purpose Bracket steel, 2 pcs</p>	•	<p><i>COMING SOON!</i></p>  <p>68002-25 1.8 Nm Tubular Lithium iOn Motor, 3-year warranty Use with Forest controls</p>
•	 <p>43036-90 Soft Shade Roller Clip</p>	•	 <p>78003-25 Micro USB Charging Cable for 68002-25</p>
•	 <p>49006-25 Fiberglass Spines, 19' 3/16" diameter</p>	•	 <p>52931-25D white 59D black Diamond Sense Remote RF, 15 channel w/ holder, Range 98'.</p>
•	 <p>49005-25 Bottom weight, 19' aluminum 1" x 1/8"</p>	•	 <p>52933-25 white 59 black Diamond Sense Wall Switch 2 channel</p>
•	 <p>49004-25 Cord for Blind System</p>	•	<p><i>COMING SOON!</i></p>  <p>52960-25 white 59 black EasyTouch Remote RF, 6 channel</p>
•	 <p>49008-00 Shade Leveler</p>		

• Standard item in assembled sets.



PRODUCT INFORMATION

- Elegant shaped aluminum profile, with hook tape
- Quality aluminum profile - chromated, powder coated
- Easy assembly and smooth operation guaranteed
- Simple and quick installation with smart Klick® bracket
- Manual setting of the tubular motor
- Radio Frequency control
- Easy to connect to building automation systems
- Cord drums can be placed at any position in the profile
- Max fabric weight per cord roll: 8.75 lbs; total system 45 lbs*
- Maximum height 18'
- Torque: 6 Nm
- Length: 19'

ADJUSTING MOTOR

The BCS tubular motor can be adjusted remotely.



FOR USE IN

Residential and contract market, or at any location where a high quality and smooth operated motorized roman blind system is required.

MOUNTING

Wall or ceiling mount

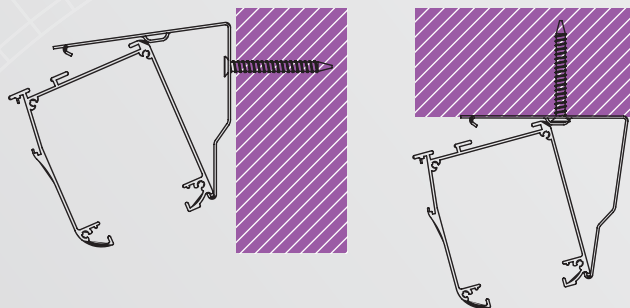

SMART FUNCTIONS

The Forest Wireless Connector is an easy way to make roman blinds 'smart'. It simply opens and closes the blinds using an analogue timer.

By using a smart plug wireless control through services such as Apple HomeKit or Google Assistant now becomes available. This RF Device can also be easily incorporated into most popular building management systems, including dry contact systems.





PROFILE

- Size 2 1/2" x 3"
- Weight 11.74 ounces/ft.
- Aluminum extrusion 6063 TS
- Finish available: white

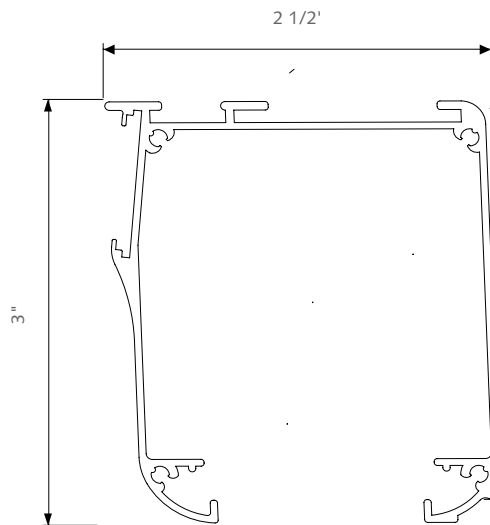

- ① BCS Klick® Bracket
- ② BCS Endcap
- ③ Counterweight bar
- ④ BCS Velcro Hook Tape
- ⑤ BCS Track
- ⑥ BCS Tube 8-angle
- ⑦ BCS Cord Roll
- ⑧ BCS Center Support
- ⑨ Forest Tubular Motor
- ⑩ Ceiling Swivel Bracket

