



**MANUAL
OPERATION**

FOREST CS & CM Tracks

CS® Contract System Track and CM Ceiling Mount Track

FOREST CS® Contract System Track
FOREST CM Ceiling Mount Track

THE WORLD
BEHIND
YOUR
DRAPERIES



FOREST CS® & CM



Scan for more information
on FOREST Track Systems

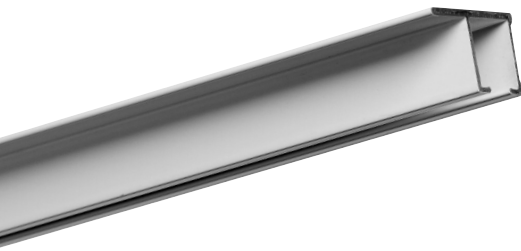
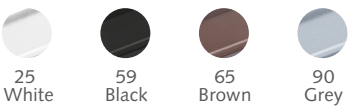

CS® CONTRACT SYSTEM CM CEILING MOUNT TRACK

- Heavy duty aluminum extrusion, powder coated, and lubricated with a patented process.
- Maximum weight is 6 lbs/ft.
- CS track can be bent and curved. An exact size template is required.
- Hand or baton draw, one or two way.
- Stackback: Ripplefold - 6" per width, pinchpleat - 7" per width, cubicle - 5" per width.

ASSEMBLED SET





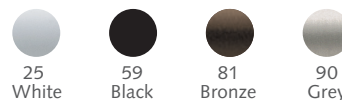

Includes track, masters, pinchpleat or ripplefold carriers, brackets, and 36" white fiberglass baton.



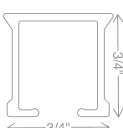
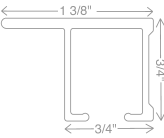
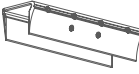



BATON OPTIONS

White fiberglass batons are available in 36", 48", 60", and 72" lengths. See all baton options, including the finishes below, at the end of brochure.



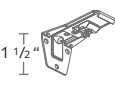
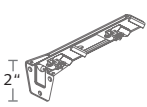

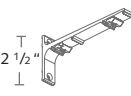







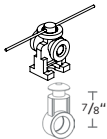

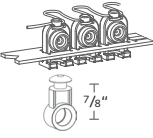
FOREST CS® & CM

CS	CM	COMPONENT
●		 <p>CS Contract System Track 51012-25 white 12' 51014-25 white 14' 51016-25 white 16' 51020-25 white 20'</p> <p>51016-59 black 16' 51020-59 black 20' 51016-65 brown 16' 51016-90 grey 16'</p>
●		 <p>CM Ceiling Mount Track 51212-25 white 12' 51214-25 white 14' 51216-25 white 16' Holes every 16"</p>
●		 <p>3906-25 59 black, 65 brown, 90 grey Track Connector</p>
●		 <p>55090-25 90° Pre-Bent CS Corners 24" x 24"</p>
●	●	 <p>52304-25 59 black, 65 brown, 90 grey End Cap - Short reduces light gap</p>
●	●	 <p>52301-25 59 black, 65 brown, 90 grey End Cap w/ Economy Slide Add 2004-25 w/ Ripplefold</p>
●	●	 <p>52302-25 Right Return 52303-25 Left Return End Cap w/ Return Plate, Snap for pinch pleat or Ripplefold</p>
●		 <p>9100-00 Channel Protector</p>
●		 <p>3001-25 59 black 90 grey Regular Duty Ceiling Bracket</p>

CS	CM	COMPONENT
●		 <p>3901-25 59 black, 90 grey Ceiling Splice/Bracket</p>
●		 <p>3003-25 59 black, 65 brown, 90 grey Heavy Duty Ceiling Bracket w/ Smart Klick</p>
●		 <p>30031-25 59 black, 65 brown, 90 grey Ceiling Bracket Cover use with 3003-XX</p>
●		 <p>53202-25 59 black, 65 brown, 90 grey 3" Smart Klick Wall Bracket w/ wide base, adjusts 3-4.5"</p>
●		 <p>53206-25 59 black, 65 brown, 90 grey 6" Smart Klick Double Wall Bracket w/ wide base adjusts 2.5"-4" & 6"-7.5"</p>
●		 <p>3280-25 59 black, 65 brown, 90 grey 3" Wall Bracket, heavy duty projection 2 1/2"</p>
●		 <p>3281-25 59 black, 65 brown, 90 grey 6" Double Wall Bracket, heavy duty projection 1 1/2", 5 1/2"</p>
●		 <p>32801-25 59 black, 90 grey Wall Bracket Cover use with 3280 & 3281</p>

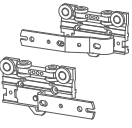

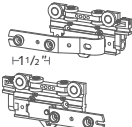

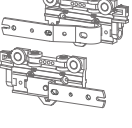



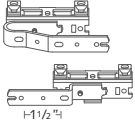
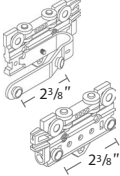
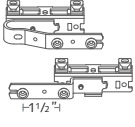

● Standard item in assembled sets.

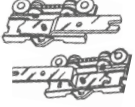
FOREST CS® & CM

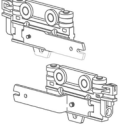
CS	CM	COMPONENT	CS	CM	COMPONENT
●	●	 <p>Wheeled Connected Snap Carrier with pendant, in plastic sleeve 2107-25, 59 black 60% fullness, 2 5/8" OC 2106-25, 59 black 65 brown, 90 grey 80% fullness, 2 3/8" OC 2105-25, 59 black 100% fullness, 2 1/8" OC 2108-25, 59 black 120% fullness, 1 7/8" OC</p>	●	●	 <p>52108-25 Stop Carrier prevents slide back</p>
●	●	 <p>Wheeled Connected Snap Carrier with pendant, on plastic strip 2207-25 60% fullness, 2 5/8" OC 2206-25, 59, 65, 90 80% fullness, 2 3/8" OC 2205-25 100% fullness, 2 1/8" OC 2208-25 120% fullness, 1 7/8" OC</p>	●	●	 <p>52100-25 59 black, 65 brown, 90 grey Ball Bearing Carrier w/ Stainless Hook slim line - use w/ grommets</p>
●	●	 <p>2007-25 59 black Pendant for Snap Tape Carrier</p>	●	●	 <p>52005-25 Button Slide Carrier</p>
●	●	 <p>2008-25 59 black, 65 brown, 90 grey Short Pendant for Snap Tape Carrier</p>	●	●	 <p>52105-25 Button Slide Carrier w/ Hook</p>
●	●	 <p>2004-25 59 black, 65 brown, 90 grey Snap Carrier for accordiafold</p>	●	●	 <p>52502-25 Overlap R 52504-25 Underlap L 59 black Standard Multi-Functional Master Use stiffener w/ exposed baton or hooks w/ hidden baton</p>
●	●	 <p>52002-25 59 black, 65 brown, 90 grey Slim Line Ball Bearing Carrier</p>	●	●	 <p>52502-25A Overlap R 52504-25A Underlap L 59A black Standard Multi-Functional Master w/ snaps and baton adaptor</p>
●	●	 <p>52008-25 59 black, 65 brown Slim Line Klick Carrier draperies hang to conceal track</p>	●	●	 <p>52502-25B Overlap R 52504-25B Underlap L Standard Multi-Functional w/ baton adaptor for stiffener. Stainless steel for outdoor use.</p>

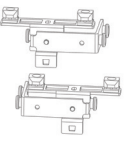
● Standard item in assembled sets.

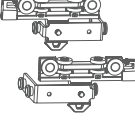
FOREST CS® & CM

CS	CM	COMPONENT	CS	CM	COMPONENT
●	●	 <p>52508-25 Overlap R 52509-25 Underlap L 59 black, 65 brown Swivel Foot Multi-Functional Master for bends and curves</p>	●	●	 <p>52601-25A Overlap R 52603-25A Underlap L Extended Spacing Master w/ snaps and adaptor</p>
●	●	 <p>52508-25A Overlap R 52509-25A Underlap L 59 black, 65 brown Swivel Foot Multi-Functional Master w/ snaps</p>	●	●	 <p>2552-25 6" Extension Arm for master Use w/ two one-way draws</p>
●	●	 <p>52501-25 Overlap R 52503-25 Underlap L Stiffener Master</p>	●	●	 <p>2551-25 Small Extension Arm</p>
●	●	 <p>52401-25 Overlap R 52403-25 Underlap L Stiffener Master w/ snaps and adaptor</p>	●	●	 <p>2305-25 59 black, 65 brown, 90 grey Twist On End Stop</p>
●	●	 <p>52410-25 Butt R 52409-25 Butt L 59 black Standard Butt Master w/ snaps and for baton use</p>	●	●	 <p>2308-25 Return Plate reversible, 2 1/2" return</p>
●	●	 <p>52411-25A Butt R 52412-25A Butt L 59A black, 65A brown, 90A grey Wheeled Butt Master w/snap adaptor Designed for hidden baton</p>	●	●	 <p>52307-90 End Lock</p>
●	●		●	●	 <p>54110-25 36" Fiberglass Baton w/ snap</p>

● Standard item in assembled sets.

FOREST CS® SPECIFICATIONS



PRODUCT INFORMATION

- Heavy duty hand drawn system for medium and heavy draperies.
- Bendable; CS track can be curved and reversed curved using an 8" radius or continuous curve.
- Heavy duty clickable carriers - 10 carriers on a breakaway strip - UV protected. Can also be used with ball bearing carriers.
- Ideal for use with overlap masters and batons which can be mounted behind or in front of draperies.
- Can also be used for the Forest Easyfold System and accordiafold drapery.
- Recommended maximum fabric weight: 6 lbs per foot depending on application.
- Finish colors available: white, black, brown and silver.
- Track finish: chromated powder coating with a factory applied patented dry lubricant.
- Available lengths: 12', 14', 16', and 20'.
- Limited lifetime warranty.

- 1 CS Track
- 2 Carrier
- 3 Master Carrier R/L Overlap
- 4 Master Carrier R/L Underlap
- 5 Carrier
- 6 Endcap with Screw

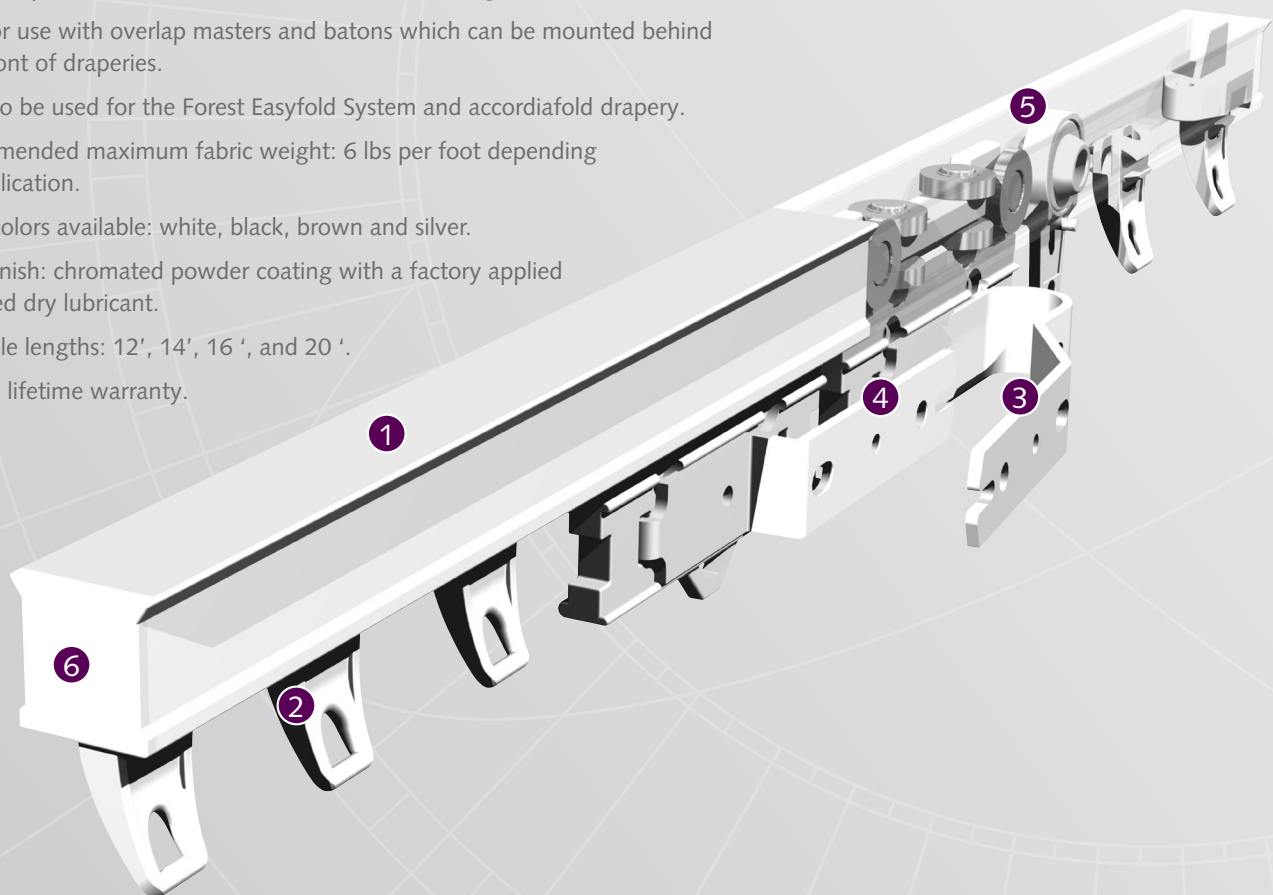



PROFILE

- Weight: 2.53 ounce per ft.
- Aluminum Extrusion
- Dimensions: 3/4" x 3/4"

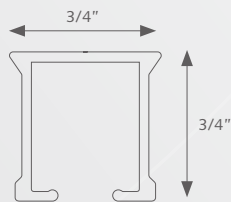

FOR USE IN

Hotels, offices, schools, healthcare facilities, residences or at any location where a heavy duty hand drawn system is required.

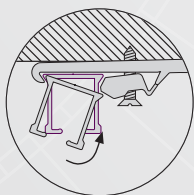

Easy installation
click - position - tighten

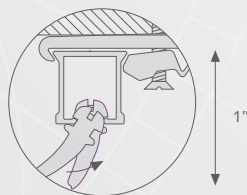

clickable carrier

BENDING / CURVING

The track can be curved and reversed curved using a 6" or 8" radius. Continuous curving is also possible with the electrical bending tool. Actual size template is required.



APPLICATIONS

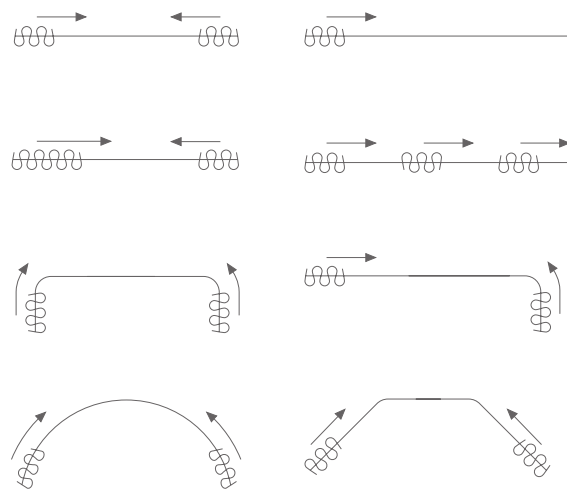

CLICK-ON STIFFENER

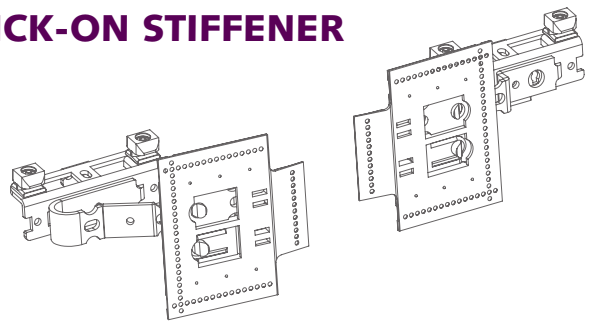

FOREST CS® SPECIFICATIONS

MOUNTING BRACKETS

Brackets need to be placed every 24".

Heavy Duty Ceiling Bracket with Smart Klick 3003-XX

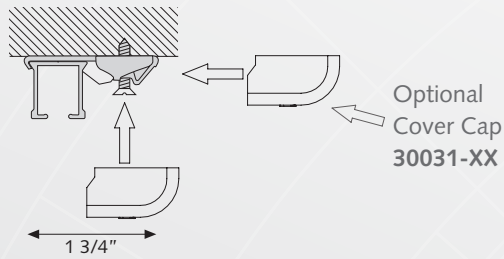

3" Smart Klick Wall Bracket 53202-XX

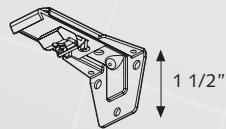

6" Smart Klick Double Wall Bracket 53206-XX

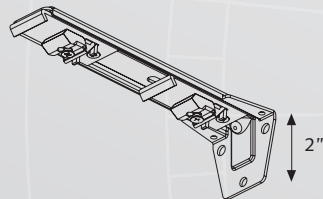

3" Wall Bracket for Wood Poles 3280-XX

A) 3" B) 2 1/2"

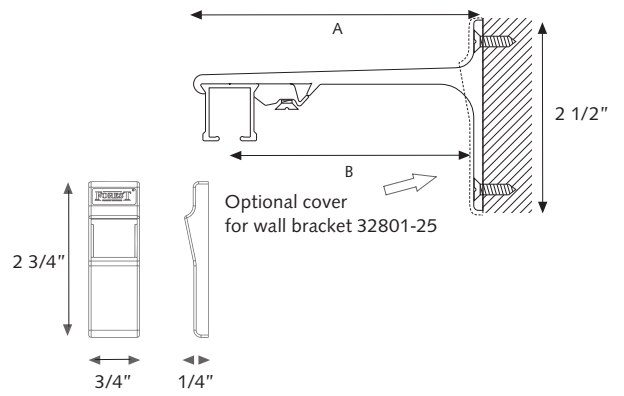





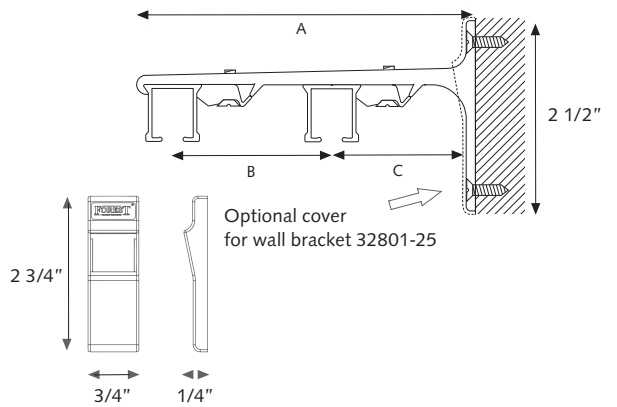







6" Double Wall Bracket for Wood Poles 3281-XX

A) 6" B) 3 5/8" C) 1 3/4"







FOREST BATONS

FIBERGLASS, ACRYLIC, ADA & COMPONENTS

BATONS	COMPONENT	BATONS	COMPONENT
 	3/8" Fiberglass Baton Must order screw separately 36" 54110-25 white w/ snap 54310-25 white w/ adaptor 54110-59, 81, 90 w/ snap 48" 54111-25 white w/ snap 54311-25 white w/ adaptor 54111-59, 81, 90 w/ snap 60" 54112-25 white w/ snap 54312-25 white w/ adaptor 54112-59, 81, 90 w/ snap 72" 54113-25 white w/ snap 54313-25 white w/ adaptor 54113-59, 81, 90 w/ snap 84" 54114-25 white w/ snap 96" 54115-25 white w/ snap	 	1/2" Clear Acrylic Baton Must order screw separately 36" 54510-00 w/ snap 54710-00 w/ adaptor 48" 54511-00 w/ snap 54711-00 w/ adaptor 60" 54512-00 w/ snap 54712-00 w/ adaptor 72" 54513-00 w/ snap 54713-00 w/ adaptor
	ADA Clear Acrylic Baton 		48" 54911-00 w/ adaptor
			9013-00 Baton Holder, clear acrylic
			54001-16 Baton Snap
			9015-00 Hex Head Shoulder Screw for baton w/ adaptor
			54000-16 D-Ring
	Colors available for 3/8" Fiberglass Batons  25 White  59 Black  81 Bronze  90 Grey		

DECORATIVE METAL & WOOD

 29MWAND-XX 40" Metal Baton	 29AWAND-16 40" Round Metal Baton Stainless Steel	 29SWAND-16 40" Square Metal Baton Stainless Steel	 29IWAND-XX 40" Wrought Iron Baton	 19WWAND-XX 40" Wood Baton	 19CWAND-XX 40" Modern Baton
--	--	---	--	---	--